

Reefast 1000

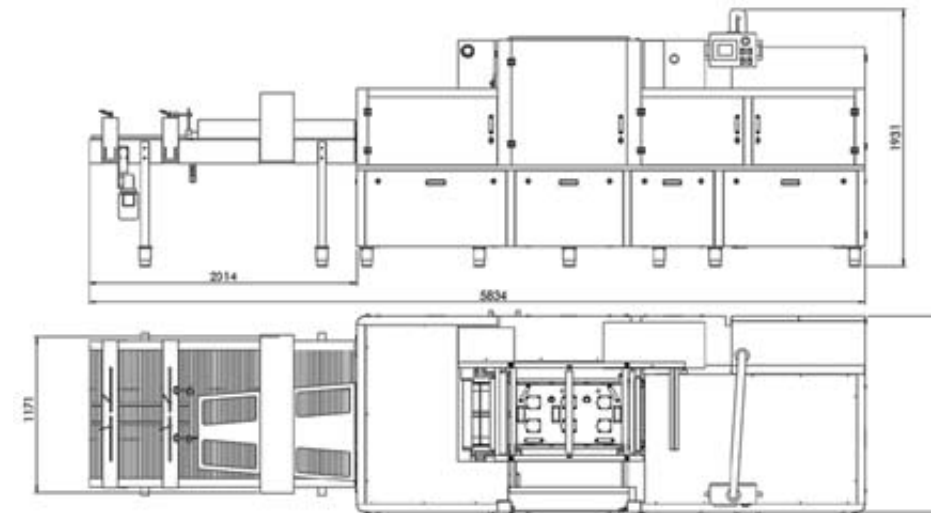

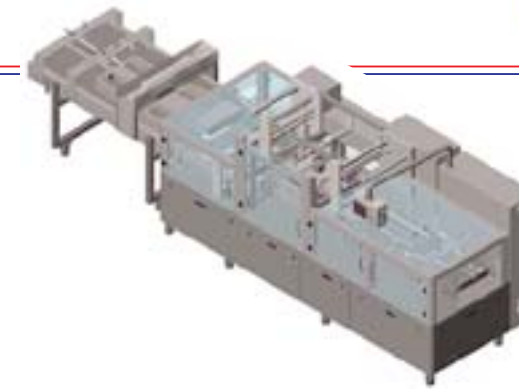
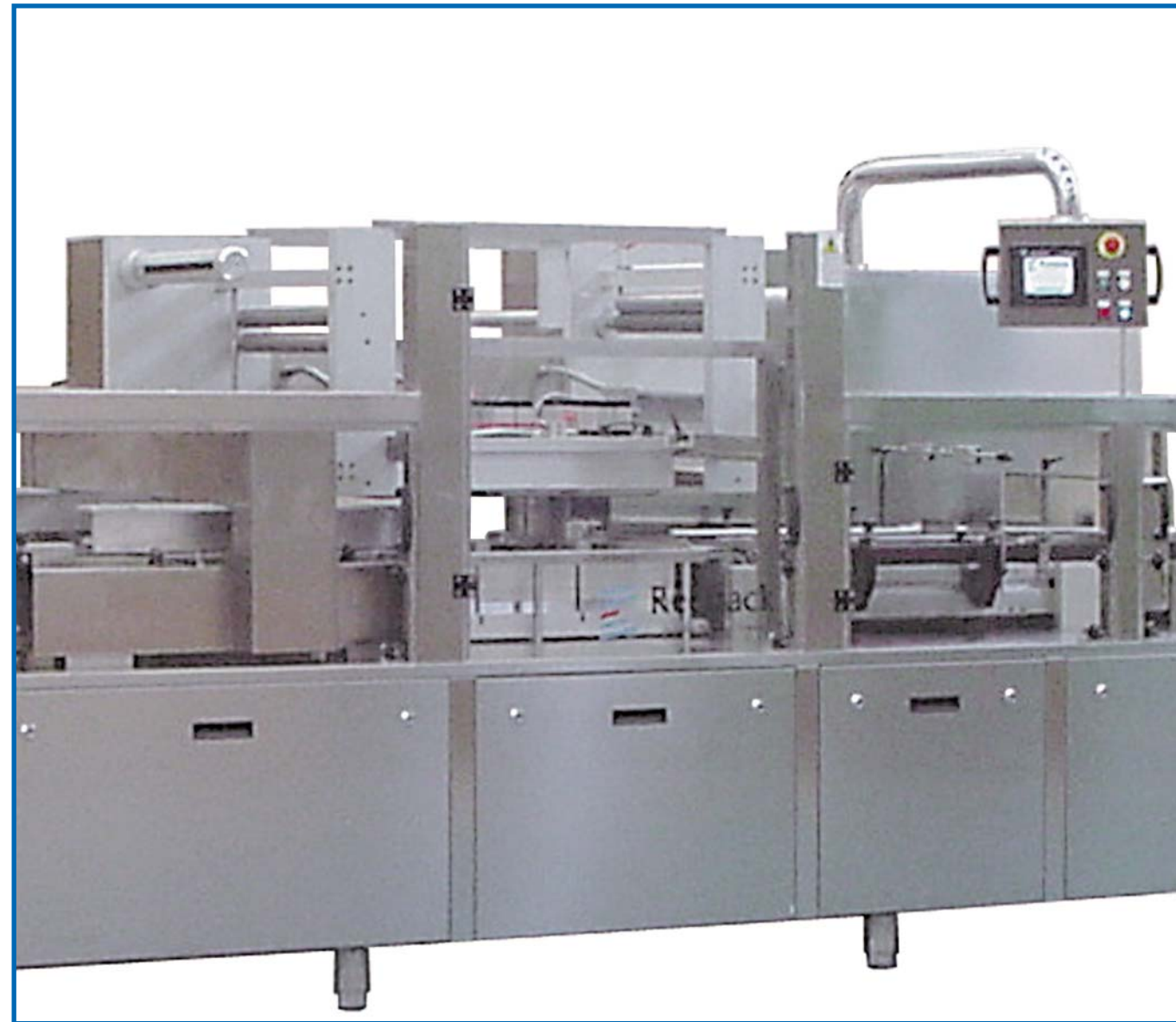

dati tecnici	technical data	technisches daten	dates techniques	Reefast 1000
dimensioni totali	Overall dimensions	Abmessungen complete	dimensions totale	5834x1475x1931±40 mm
dimensioni macchina	machine dimensions	Abmessungen der Maschine	dimensions de la machine	3820 mm
dimensione divisore	deviateur dimensions	Abmessungen der scheid	dimensions du diviseur	2014 mm
lunghezza piano carico vaschetta	length of loading area	Länge des Einlaufbands	longueur plan de chargement	1800 mm
altezza piano di carico	height of loading area	Höhe max	hauteur machine	950±40 mm
peso totale incl.pompa vuoto	weight incl.pump	Gewicht mit Pumpe	pois avec pompe à vide	ca.1500 Kg.
max dimensione vaschetta	max tray dimensions	Max Abmessungen der Schale	dimensions maxi de la barquette	255 x 265
max profondità vaschetta	max tray depth	Maximale Tiefe der Schale	profondeur maxi de barquette	100 mm
max larghezza film sigillatura	max width of top web	Maximale Oberfolienbreite	laize maxi du film d'operculag	500 mm
max diametro bobina film	max diameter of web roll	Maximale Durchmesser Folienrolle	diamètre maxi de la bobine film	400 mm
diametro mandrino bobina	diameter of web roll mandrel	Durch. des Folienaufnahmedorns	diamètre mandrin de la bobine	76 mm
pompa vuoto	Vacuum pump	Vakuumpumpe	pompe à vide	250m ³ /h (standard)
alimentazione elettrica	electrical supply	Elektrischer Anschluss	raccordement électrique	3/N/PE 400V - 50Hz
assorbimento	power consumption	Mittlere Leistung	puissance électrique	min.4 Kw - max. 30 Kw *
aria compressa	compressed air	Pressluft	air comprimé	7bar - 270NL/min
nr.cicli macchina	machine capacity	Leistung der Maschine	cadence de la machine	8-15 cicli/min

*valori espressi a minimo e massimo carico con stampo singolo o multiplo *values expressed at min. and max. loading with single or multiple sealing tool

**Automatic Tray Sealing Machine
with Multi-Vacuum Chambers**

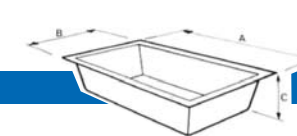
**capacità stampo
die-set capacity**



Reefast 1000 double line	
A 255 x B 265 x C 100 mm.	A 255 x B 195 x C 100 mm.
	

Si riserva la facoltà di apportare modifiche e dati esposti senza alcun preavviso / In keeping with improvements, designs and specification subject to change without notice / Sie dürfen nicht als Übernahme irgendeiner Gewährleistung betrachtet und es können keine Verpflichtungen für uns daraus hergeleitet werden / Nous nous réservons, dans le cadre de notre politique de développement permanent, le droit de les modifier sans préavis

Reefast 1000

GENERAL STANDARD FEATURES

- Full Colour Touch-Screen control panel, programmable and movable on a multiple position pivot arm.
 - Storage up to 50 custom programs for tray and/or product types.
 - Conveyor chain 3/4" in stainless-steel.
 - Servo-driven indexing system
 - Integral Converger System for single lane discharge.
 - Quick down tool and Sealing head change-over.
- Contoured Filler Plates in Tool Chamber for reducing evacuation times and Gas consumption.
 - Pneumatic shaft for quick release of the film reel.
- Film winding for big reel up to 500mm width with external diameter by 400mm.
- Film rewinding controlled by inverter with one motor gear+one for rewinding scrap film.
 - All machine parts water-proof IP65.
- Stainless Steel Open-Frame Construction for easy cleaning and maintenance.
 - Fully compliant with European standards/regulations (CE).

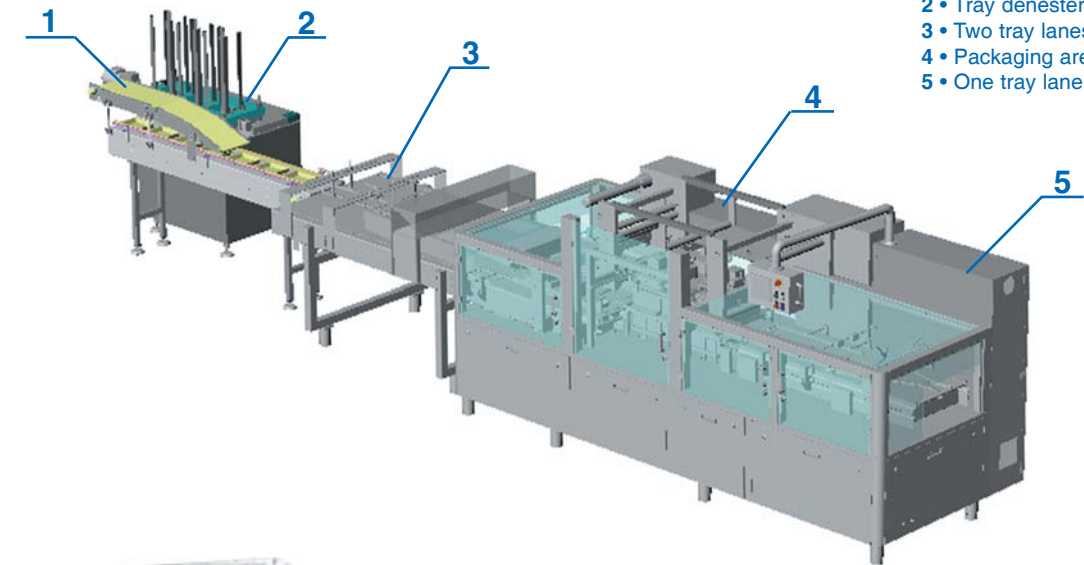

- 1 • Product feeding conveyor
- 2 • Tray denester
- 3 • Two tray lanes divider
- 4 • Packaging area
- 5 • One tray lane conveyor

